

Thank you for purchasing this Dynojet kit. This kit has been developed for a motorcycle which is set to the parameters listed at the right in the "Stage" description. If your motorcycle does not meet any of these parameters please check with Dynojet before installation. For technical assistance contact your Dynojet distributor or call Dynojet U.S.A. (800)-992-4993

2191 Mendenhall Dr. Suite 105  
 North Las Vegas, NV 89081  
 TEL: 702-399-1423  
 FAX: 702-399-1431  
 8am-5pm Pacific Time  
 Monday through Friday

Website Address  
<http://www.dynojet.com>

The manufacturer and seller make no warranties express or implied which extend beyond the description of the goods contained herein. Any description or this product is for the purpose of identifying it and shall not be deemed to create an express warranty.



**3128.001**

U.S Models Only

1989-2000 Suzuki GS500E

**Stage 1&3**

**STAGE 1**

For mildly tuned machines using the stock airbox, with stock or K&N filter #SU-0051

**STAGE 3**

For mildly tuned machines using individual filters or velocity stacks. K&N filters #RU-2970

Both stages may be used with a good aftermarket exhaust

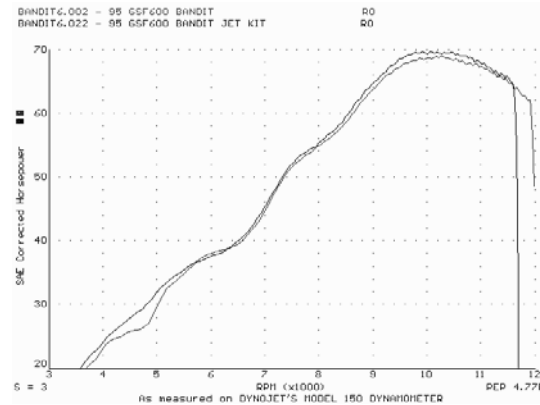

This graph shows a typical gain with a Dynojet jet kit.

# WARNING

**NO SMOKING!  
 NO OPEN FLAME!  
 WHILE INSTALLING  
 YOUR DYNOJET KIT**

Parts List		
2	Main Jet	DJ118
2	Main Jet	DJ122
2	Main Jet	DJ128
2	Main Jet	DJ134
2	Fuel Needle	DNO348
2	Adjusting Washer	DW0001
2	E-clips	DE0001
2	Slide Orifices	DCO350
2	Slide Orifices	DCO351
1	Tap	DT1024
1	Plug Drill	DD #5/32
1	Screw	DS0001

## STAGE ONE INSTRUCTIONS

1. Remove the vacuum slides from the carbs. Remove the stock needles and spacers, noting order of assembly (Fig.A).
2. Use the 5/32 drill bit to enlarge both slide lift holes on each slide (Fig A). With tap provided (DT1024) tap both slide lift holes on each slide. Install corrector DCO350 in the left hole and DCO351 in the right hole (Fig. A). If correctors do not go flush cut excess off with a razor blade. For racing or hard street driving remove one corrector out of each slide for better acceleration.
3. Install the Dynojet needles on groove #2 from the top. Use all stock spacers (Fig. A). Install the small Dynojet washers above the e-clip. After installing the slides in the carbs be sure to check slide movement manually.
4. Remove the stock main jets and replace with the Dynojet main jets provided. If you are running the stock exhaust install the DJ118 main jets. If you are running an aftermarket exhaust or slip-ons with high flowing baffles use the DJ122 main jets. Be sure that the jet you are changing is the main jet.
5. Locate the fuel mixture plug (Fig. B). If you see a screw head at Fig.B then proceed to the adjusting procedure. With the 5/32 drill bit provided carefully drill through the plug. **NOTE: The mixture screw is directly underneath this plug, be ready to pull back on the drill the instant you break through.** Use screw provided to secure and remove this plug. Carefully turn the mixture screw clockwise until lightly seated, then back out 2 turns.

**Note:** If you experience fuel problems under 4000 rpm that the needle can't fix then try adjusting the float level. If you feel it is too rich then lower the fuel level. If you feel it is too lean then raise the fuel level.

## STAGE THREE INSTRUCTIONS

1. Remove the vacuum slides from the carbs. Remove the stock needles and spacers, noting order of assembly (Fig.A).
2. Use the 5/32 drill bit to enlarge both slide lift holes on each slide (Fig A). With tap provided (DT1024) tap both slide lift holes on each slide. Install corrector DCO350 in the left hole and DCO351 in the right hole (Fig. A). If correctors do not go flush cut excess off with a razor blade. For racing or hard street riding remove one corrector out of each slide for better acceleration.
3. Install the Dynojet needles on groove #2 from the top. Use all stock spacers (Fig. A). Install the small Dynojet washers above the e-clip. After installing the slides in the carb be sure to check slide movement manually.
4. Remove the stock main jets and replace with the Dynojet main jets provided. If you are running the stock exhaust install the DJ128 main jets. If you are running an aftermarket exhaust or slip-ons with high flowing baffles use the DJ134 main jets. Be sure that the jet you are changing is the main jet.
5. Locate the fuel mixture plug (Fig. B). If you see a screw head at Fig.B then proceed to the adjusting procedure. With the 5/32 drill bit provided carefully drill through the plug. **NOTE: The mixture screw is directly underneath this plug, be ready to pull back on the drill the instant you break through.** Use screw provided to secure and remove this plug. Carefully turn the mixture screw clockwise until lightly seated, then back out 2 turns.

Fig. A

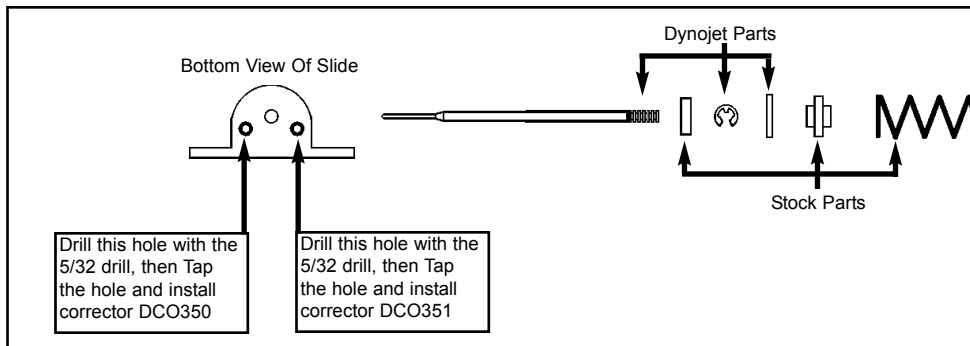

Fig. B

